



## Water Heater Installation Information



Prevent gas leaks and water damage during an earthquake by properly securing your water heater as outlined in this bulletin.

No permit is required for seismic bracing of existing water heaters.

This bulletin pertains to storage-type water heaters. For safety, obtain a building permit. Follow all specifications and regulations when you locate or replace a water heater.

### NATURAL GAS WATER HEATERS - REQUIREMENTS

**Prohibited locations.** Gas-fired water heaters use fuel combustion for heat. For safety, do NOT install them in bathrooms, clothes closets, rooms used for sleeping, or in any closet or confined space that opens into a bathroom or bedroom. *Exception:* Direct vent water heaters.

**Under stairways and landings.** Where not prohibited by other regulations, water heaters may be located under a stairway or landing.

**In a basement.** See page 2 for locating a water heater in a basement.

**In a garage.** Gas or electric water heaters that generate a glow, spark, or flame capable of igniting flammable vapors may be installed in a garage if the pilots, burners, or heating elements and switches are elevated at least 18 inches above the floor; any stand or platform base must be adequately anchored to the floor. If the water heater installed within a garage is enclosed in a separate, approved compartment that is accessed only from outside of the garage, it may be installed at floor level provided that the required combustion air is drawn from outside.

**In attics and other spaces that require a safe pan.** Locating a storage tank water heater in an attic or space where a leak could cause damage is prohibited UNLESS you install an approved safe pan below the water heater with a minimum 3/4-inch drain to an approved, readily visible location.

### STRAPPING, BRACING & ANCHORING - REQUIREMENTS

A water heater can move or tip during an earthquake, resulting in a gas piping leak or broken water lines that could flood and damage floors and walls. State law, AB 1890, requires all new and replacement water heaters sold in California on or after July 1, 1991 to be strapped, braced, or anchored as follows:

**Strapping.** Water heaters require bracing in proportion to their sizes:

\* Up to 52-gallon size - Requires 2 straps:

*Upper strap* - Place 9 inches from the top of the unit or within the upper one-third of the unit.

*Lower strap* - Place at least 4 inches above the controls and within the lower one-third of the unit.

\* 75-gallon unit - Requires 3 straps

\* 100-gallon unit - Requires 4 straps

\* Another strap must be added for every additional 25 gallons in size.

Some manufacturers make listed straps for water heater installations; these may be used instead of the methods discussed below when installed per the manufacturer's instructions.

**Bracing.** Division of the State Architect (DSA) recommends using one of these bracing methods:

*Tape Method* - Use minimum 24-gauge plumber's tape to encircle the water heater and use lag screws to bolt it to a 2x4-inch ledger (required) that is bolted to the wall framing.

*Conduit Method* - Use a round thinwall conduit along with minimum 24-gauge plumber's tape, bolts, and lag screws.

**Anchoring.** Follow the instructions provided by the water heater manufacturer.

### Building Division

Community Development  
Department

City of Oroville  
1735 Montgomery St  
Oroville, CA 95965  
(530) 538-2401  
[www.cityoforoville.org](http://www.cityoforoville.org)

*continued >*

## TEMPERATURE AND PRESSURE RELIEF (T&P) VALVE - REQUIREMENTS

In addition to primary temperature controls, storage-type water heaters and hot water boilers must have a combination **temperature and pressure relief valve** (T&P valve) that is constructed, listed, and installed in accordance with nationally recognized standards and the following requirements:

1. Each T&P valve must be an approved type with a drain.
2. A union must be installed in the drain line near the water heater to facilitate removal and replacement of the water heater or the T&P valve. *Exception:* If a water heater can be replaced without adversely affecting the drainpipe installation, the union may be omitted.
3. No shutoff valve shall be installed in the relief valve drain line system.
4. The drain provided from T&P valves must not be smaller than the relief valve outlet, and must be made from galvanized steel, hard-drawn copper piping and fittings, OR be a listed relief valve drain tube with fittings that will not reduce the internal bore of the piping.
5. The piping shall extend from the valve to the outside of the building with the end of the pipe pointing downward, not more than 2 feet nor less than 6 inches above the ground. It is not acceptable to terminate the T&P in the underfloor area.
6. When a water heater is located in a garage, the T&P drainpipe may terminate in the garage. The piping must extend from the valve to within 12 inches but not less than 6 inches above the floor and point downward.
7. Water heaters not located in a garage cannot terminate the T&P drain in the garage. These drain lines must terminate to the outside.
8. T&P drainage piping must run independently from other drainage piping. For example, it is not acceptable to combine T&P drains with A/C condensate drainage piping or water heater drain pan piping. Also, it is not acceptable to terminate the T&P drain into a water heater drain pan.
9. The T&P drain must not be connected to the sanitary sewer.
10. No part of such drain shall be trapped.
11. The terminal end of the drainpipe must not be threaded.
12. For water heaters installed in a basement or in locations where it is not possible for the T&P relief to achieve gravity drainage, a special provision for drainage is allowed, see page 3.
13. You must install an expansion tank in a closed system, such as a house with a pressure reducing valve at the water service.

## WATER HEATER INSTALLATION IN A BASEMENT - REQUIREMENTS

Follow these specifications outlined and illustrated below when installing a water heater in a basement:

1. 3/4" tee with 1/8" reducer
2. 1/8" tubing, drip coil with slightly crimped end
3. 3" minimum slab or base
4. 3/4" union within 12"
5. Hot water line (insulated first 5')
6. Cold water line with shutoff valve (insulated first 5')
7. Terminate not less than 6" and not more than 24" at exterior
8. Gas supply line with sediment trap, downstream of shutoff valve
9. 3/4" CPVC or copper tubing, 1/4 per foot slope toward termination
10. Seismic straps, listed for size or use 24g straps (50gal: 2 straps, 75gal: 3 straps, 100gal: 4

### Permits and inspections

- Help keep your property safe
- Help assure the quality of your remodeling investment
- Are required by law

We'll answer your questions about permits.

Contestaremos sus preguntas referente a permisos en Español.

### Building Division

#### Community Development Department

City of Oroville  
1735 Montgomery St  
Oroville, CA 95965  
(530) 538-2401  
[www.cityoforoville.org](http://www.cityoforoville.org)

*continued >*

11. Vent connector: Single appliance vent with maximum horizontal length 75% of vertical for single wall, 100% for b-vent
12. Expansion tank if required per CPC 608.3

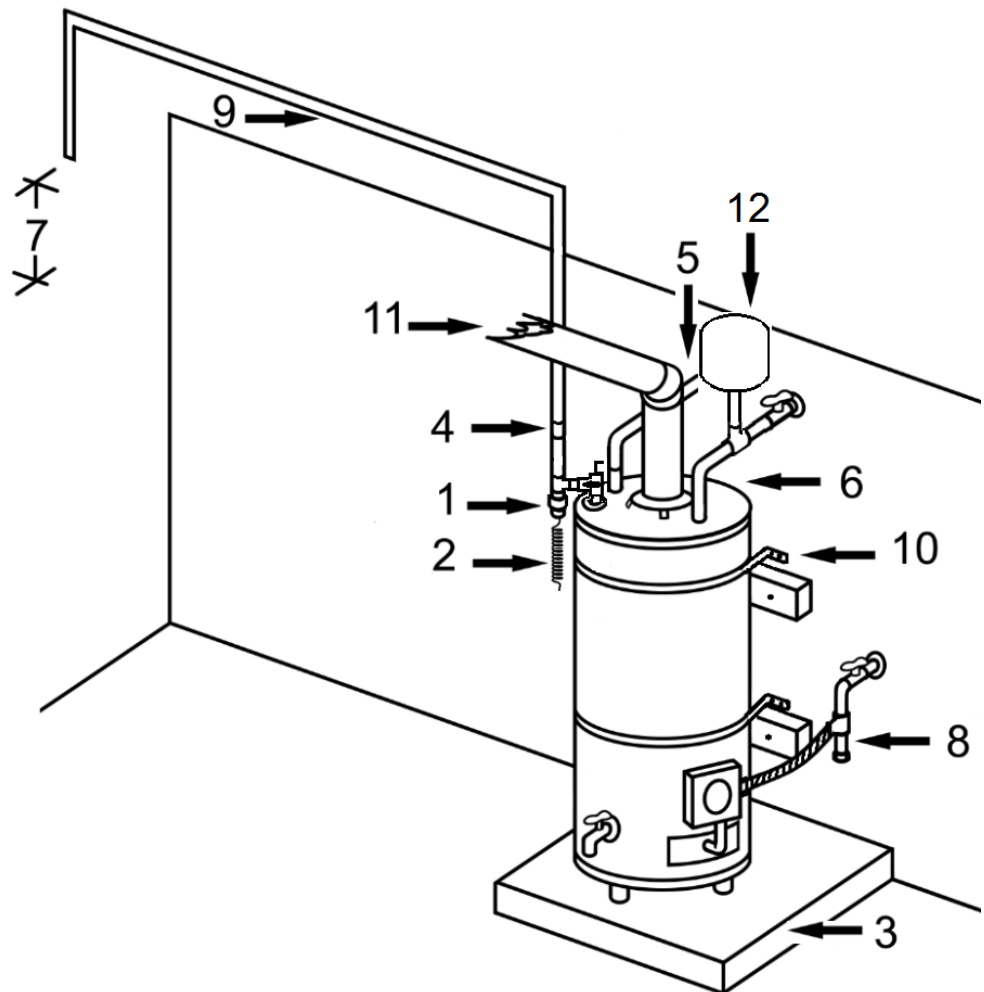

**WATER HEATER INSTALLATION IN GARAGE - REQUIREMENTS**

Water heaters installed in a garage and located in the path of vehicles shall be protected by a barrier post. The post shall be of steel, 4-inches in diameter, and concrete filled, set not less than 3ft above ground, and located not less than 3ft from the water heater.

**WATER LINE INSULATION**

The first 5ft of the hot and cold water lines from the water heater shall be insulated with 1 inch of R-4 insulation.

**TANKLESS WATER HEATERS - REQUIREMENTS**

Tankless water heaters shall be listed by an approved testing agency (UL, etc...) and be installed in accordance with the manufacturers installation instructions.

**INSPECTIONS - REQUIREMENTS**

One final inspection is required after all work has been completed.