

HANDICAPPED SPACES – SINGLE TYPE

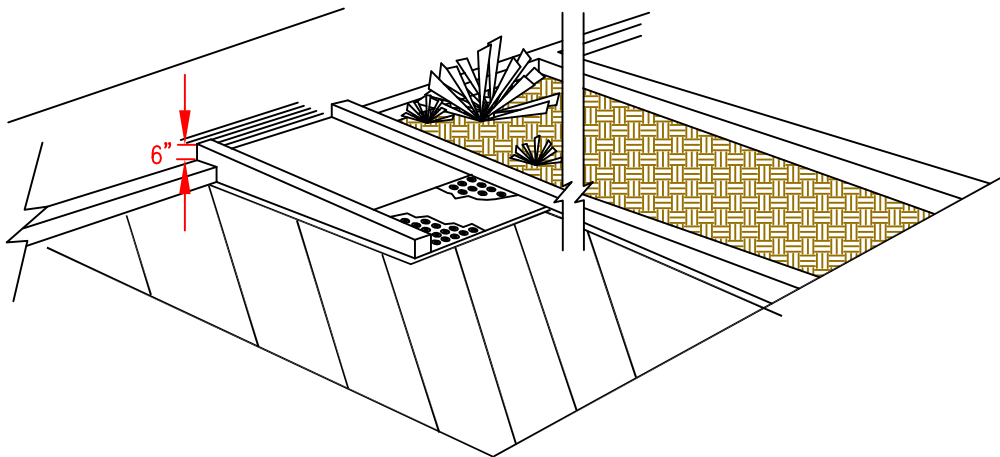

DETAIL A

SEE ST-15 FOR RAMP DETAILS



CITY OF OROVILLE DEPARTMENT OF PUBLIC WORKS		
STANDARD FOR HANDICAPPED SPACES – SINGLE TYPE		
DRAWN BY. SG	RICK WALLS, P.E. DIRECTOR OF PUBLIC WORKS DEPARTMENT	SHEET 1 OF 3 MS 04

CURB RAMP REQUIRED WHEN WALK IS AT DIFFERENT LEVEL THAN PARKING ELEVATION, MAXIMUM SLOPE 8.33%.

SEE STANDARD ST-15 1 OF 3

NOTE: RAMP ARE NOT ALLOWED TO ENCROACH INTO LOADING/ UNLOADING ZONES, PARKING SPACES OR VEHICULAR LANES.

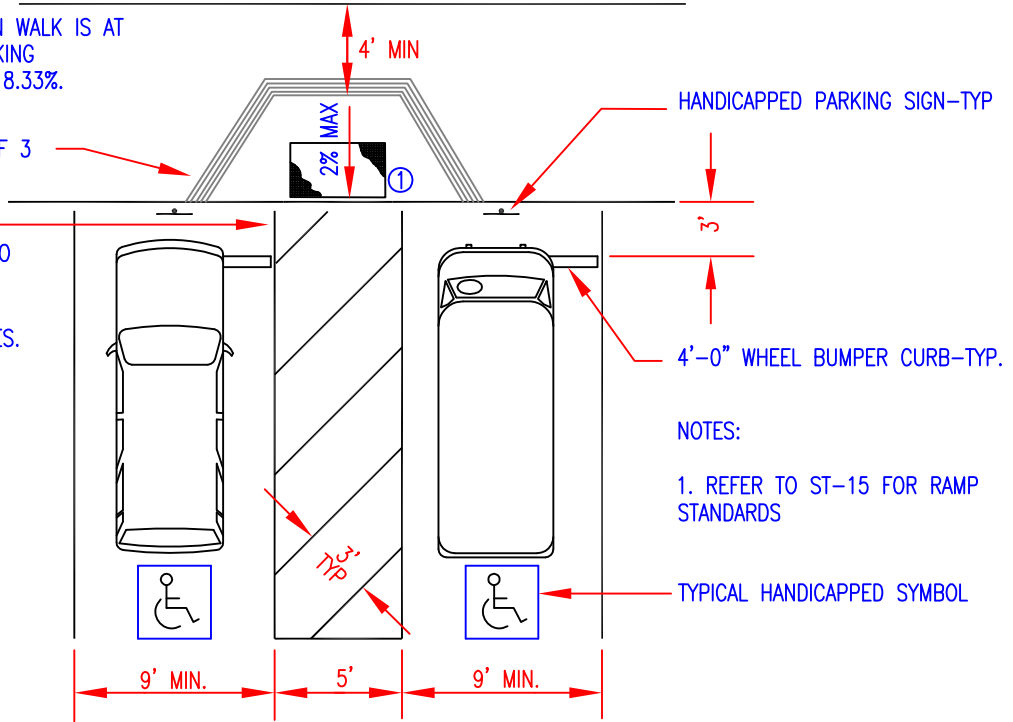

HANDICAPPED PARKING SIGN-TYP

4'-0" WHEEL BUMPER CURB-TYP.

NOTES:

1. REFER TO ST-15 FOR RAMP STANDARDS

TYPICAL HANDICAPPED SYMBOL

HANDICAPPED SPACES – DOUBLE TYPE



CITY OF OROVILLE
DEPARTMENT OF PUBLIC WORKS

STANDARD FOR
HANDICAPPED SPACES – DOUBLE TYPE

DRAWN BY.
SG

RICK WALLS, P.E.
DIRECTOR OF PUBLIC WORKS DEPARTMENT

SHEET
2 OF 3
MS 04

NOTE:
RAMPS ARE NOT ALLOWED TO
ENCROACH INTO LOADING/ UNLOADING
ZONES, PARKING SPACES OR
VEHICULAR LANES.

CURB RAMP REQUIRED WHEN WALK IS AT
DIFFERENT LEVEL THAN PARKING
ELEVATION, MAXIMUM SLOPE 8.33%.
SEE STANDARD ST-15 1 OF 3

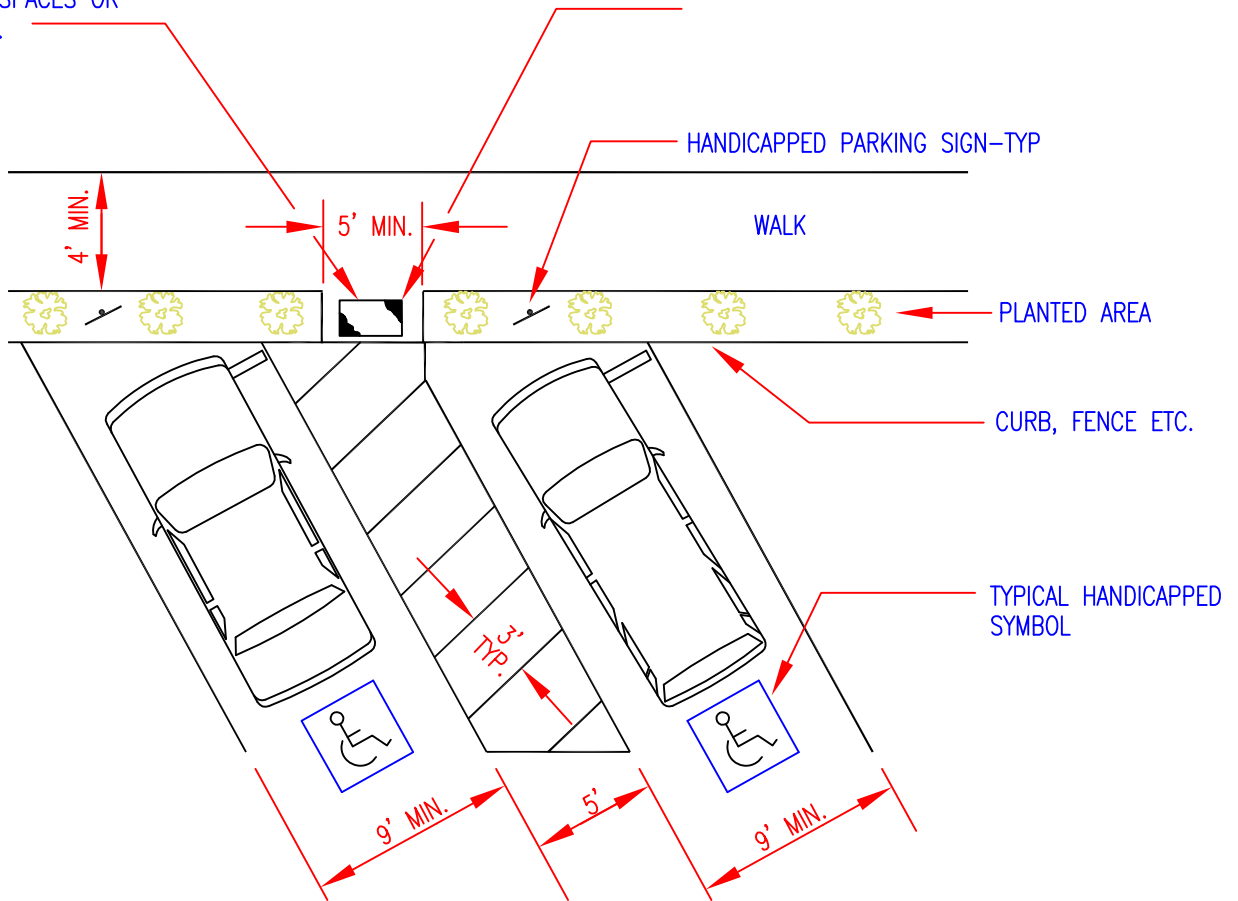

HANDICAPPED SPACES - DOUBLE DIAGONAL TYPE

NOTES:

1. HANDICAPPED SPACES SHALL BE PROVIDED PER CHAPTER 2-17 OF THE STATE BUILDING CODE. (CALIFORNIA ADMINISTRATIVE CODE, TITILE 24, PART 2)
2. HANDICAPPED SPACE MUST PERMIT USE OF EITHER OF CAR DOORS.
3. BUMPER REQUIRED WHEN NO CURB OR BARRIER IS PROVIDED WHICH WILL PREVENT ENCROACHMENT OF CARS OVER WALKWAYS.
4. WHEEL CHAIR MUST NOT BE FORCED TO GO BEHING CARS OTHER THEN THEIR OWN.
5. SURFACE SLOPES OF PARKING SPACES SHALL BE THE MINIMUM POSSIBLE TO PROVIDE ADEQUATE DRAINAGE AND SHALL NOT EXCEED 2% GRADIENT IN ANY DIRECTION.



CITY OF OROVILLE DEPARTMENT OF PUBLIC WORKS		
STANDARD FOR HANDICAPPED PARKING SPACES		
DRAWN BY. SG	RICK WALLS, P.E. DIRECTOR OF PUBLIC WORKS DEPARTMENT	SHEET 3 OF 3 MS-04