

NOTES:

1. CAST IRON FRAMES & COVER PINKERTON FOUNDRY NO. A-490 OR EQUIVALENT.
2. WHEN IN ROADWAY LEAVE CONCRETE 2" DOWN, IN OTHER AREAS SLOPE CONCRETE AWAY.
3. CORRECT SIZE OF CAULDER COUPLING IS TO BE USED TO JOIN CAST IRON FRAME AND PIPE.
4. COMPACTION AROUND PIPE TYPICAL AS PER OTHER SPECIFICATIONS.

STANDARD CLEANOUT DETAIL



CITY OF OROVILLE DEPARTMENT OF PUBLIC WORKS		
STANDARD FOR SEWER CLEANOUT		
DRAWN BY. SG	RICK WALLS, P.E. DIRECTOR OF PUBLIC WORKS DEPARTMENT	SHEET 1 OF 2 SS-12

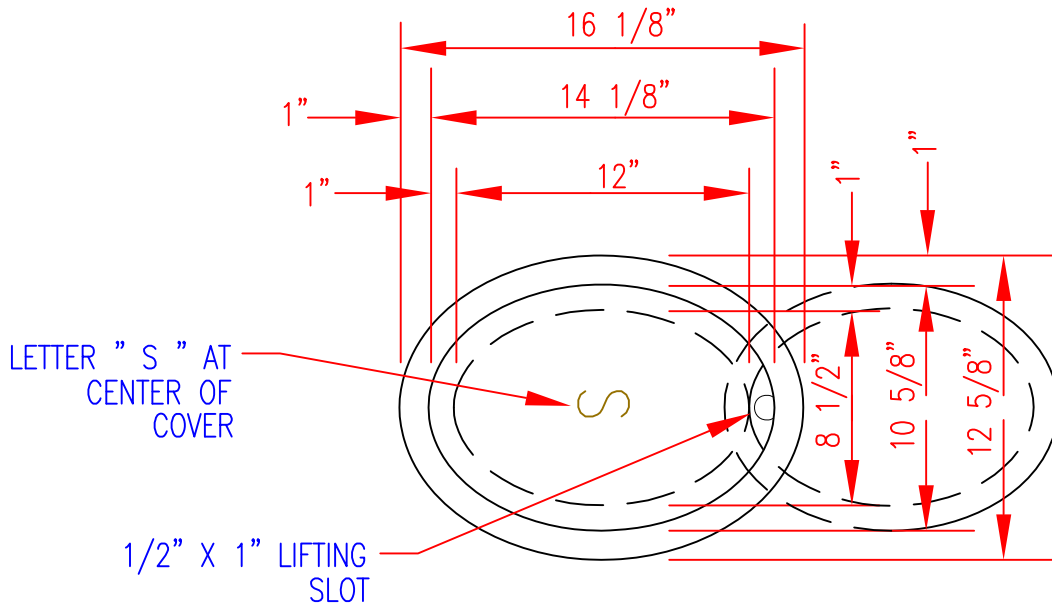

FRAME AND COVER DETAIL

NOTE:

$\frac{1}{16}$ " CLEARANCE BETWEEN FRAME & COVER

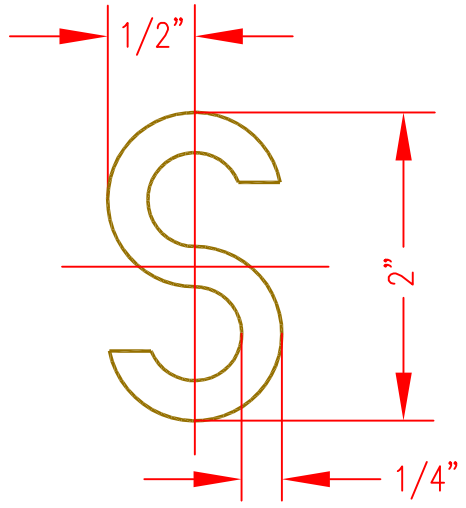

LETTER " S " AT CENTER OF COVER



CITY OF OROVILLE DEPARTMENT OF PUBLIC WORKS		
STANDARD FOR SEWER CLEANOUT		
DRAWN BY. SG	RICK WALLS, P.E. DIRECTOR OF PUBLIC WORKS DEPARTMENT	SHEET 2 OF 2 SS-12