

FRONT VIEW

8' FOOT SECTIONS SHALL BE ADDED OR DELETED TO GIVE THE FOLLOWING WIDTH :

WIDTH OF ROADWAY	NO. OF 8' SECTIONS	TOTAL LENGTH OF PANEL
68'	7'	58'
56'	6'	50'
36'	3'	26'
20' ALLEY	2'	18'

TABLE OF PANELS FOR VARIOUS ROADWAY WIDTHS

NOTE:

ENTIRE PANEL SHALL BE PAINTED WITH WHITE REFLECTIVE PAINT.  
 BLACK STRIPS OVER FULL LENGTH OF PANELS. FIVE  
 REFLECTORS SPACED AS SHOWN.



CITY OF OROVILLE  
 DEPARTMENT OF PUBLIC WORKS

STANDARD FOR  
 STREET BARRICADE

DRAWN BY.  
 SG

RICK WALLS, P.E.  
 DIRECTOR OF PUBLIC WORKS DEPARTMENT

SHEET  
 1 OF 2  
 ST-30

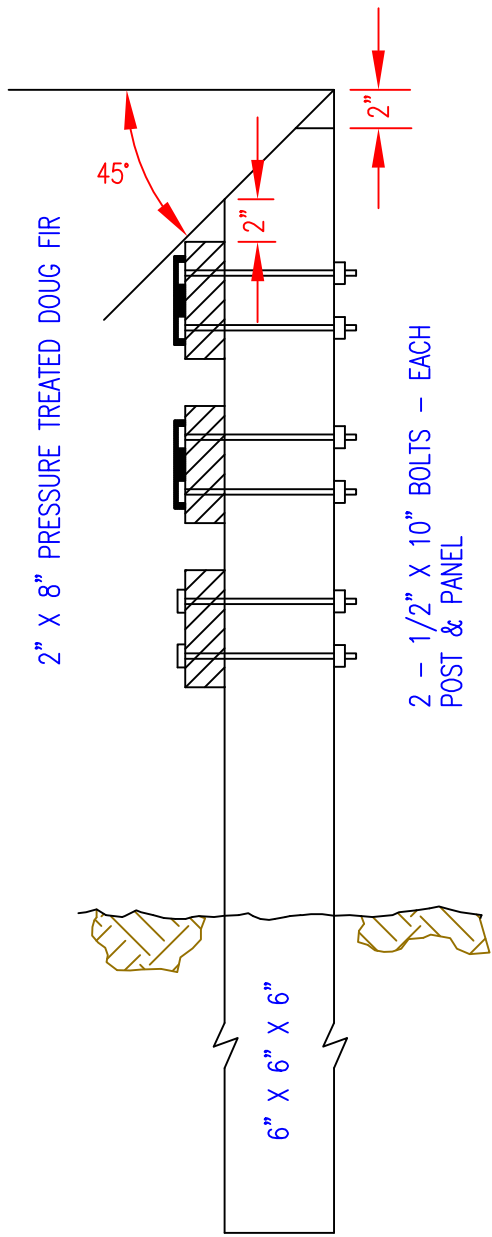

SIDE VIEW

2 1/2" GALVANIZED PIPE  
@ 4' - 0" CTRS (MAX.)

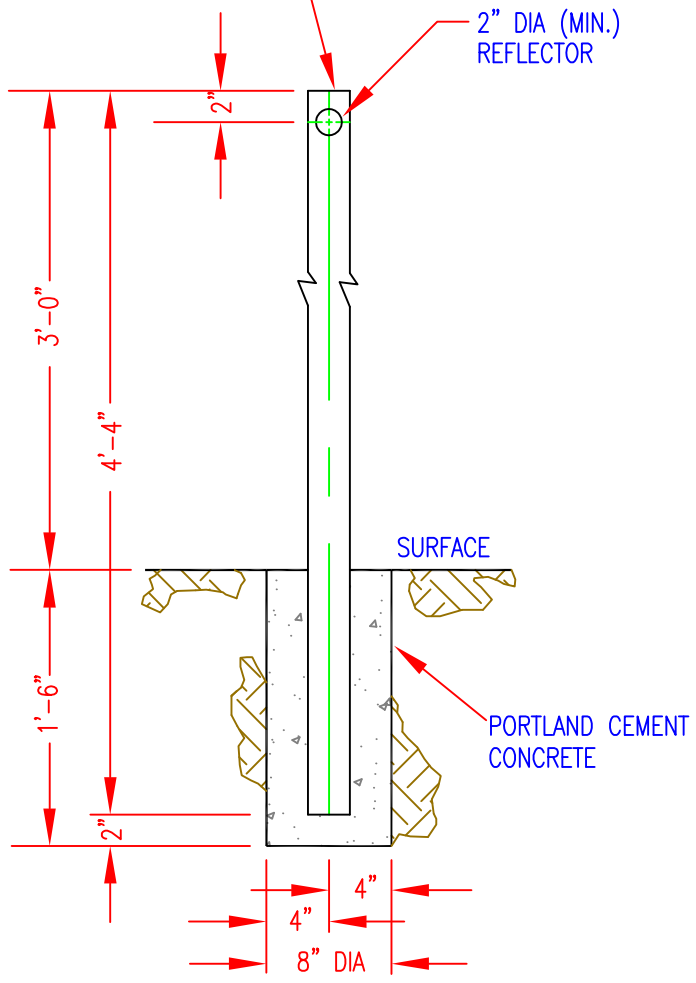

GUARD POST DETAIL



CITY OF OROVILLE DEPARTMENT OF PUBLIC WORKS		
STANDARD FOR STREET GUARD PANEL		
DRAWN BY. SG	<b>RICK WALLS, P.E.</b> <small>DIRECTOR OF PUBLIC WORKS DEPARTMENT</small>	SHEET 2 OF 2 ST-30