

END 50' RADIUS CURB RETURN

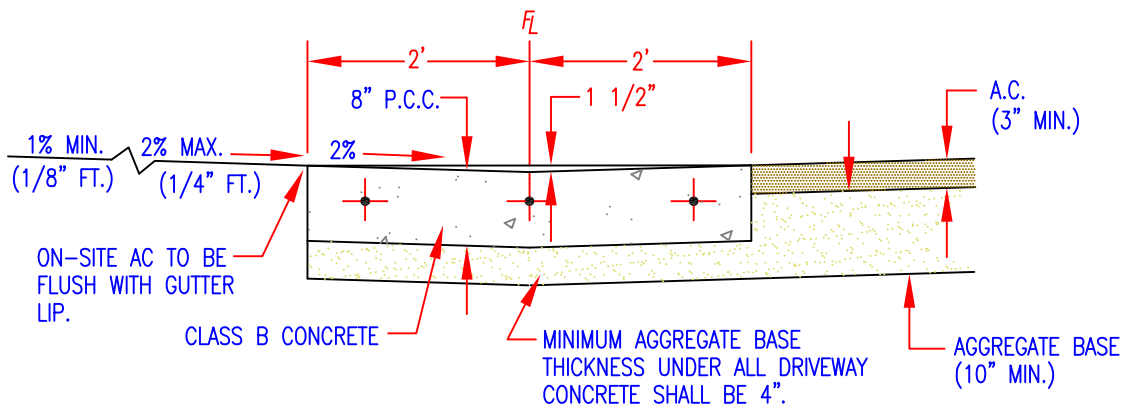

NOTES:

1. SPANDRELS AND CROSS GUTTERS SHALL CONFORM TO CITY STD. ST-08.
2. CROSS GUTTERS ARE TO BE APPROVED BY ENGINEERING.



CITY OF OROVILLE
DEPARTMENT OF PUBLIC WORKS

STANDARD FOR
CURBED ENTRANCE WITH VALLEY GUTTER

DRAWN BY.
SG

RICK WALLS, P.E.
DIRECTOR OF PUBLIC WORKS DEPARTMENT

SHEET
1 OF 1
ST-10